



MR1000 Series

Standby-compatible Partial Resonance Power Supply IC Modules

Masaaki Hayashi - Electronic Device Div.Group Advanced Power Products Div.
Device Design Dept. Assistant Manager (Joined the company in 1989)

1

Introduction

www.DataSheet4U.com

Energy conservation guidelines from the Ministry of Economy, Trade and Industry's Agency of Natural Resources and Energy place considerable emphasis on reducing standby power consumption of domestic electrical appliances. These guidelines designate domestic electrical appliances as 'special devices', and set target years and criteria for achieving these reductions based on the 'top runner' system. They are characterized by a considerable degree of severity in that, if targets cannot be achieved, manufacturers are legally required to publicly proclaim the fact, and to follow the recommendations of the Agency of Natural Resources and Energy.

Domestic electrical appliances employing remote controls are characterized by a standby time which is considerable in proportion to the duration of daily use. While the absolute value of the instantaneous power consumption is low, the proportion of standby power consumption within the total annual power consumption is large, and demands for a reduction in standby power consumption are therefore becoming increasingly vociferous.

The MR1000 Series products introduced in this paper are standby-compatible partial resonance power supply IC modules consisting of a multi-chip module (MCM) comprising a control IC and two MOSFET chips. The ability to develop a standby-compatible partial resonance power supply with a minimum of external components facilitates a reduction in design time.

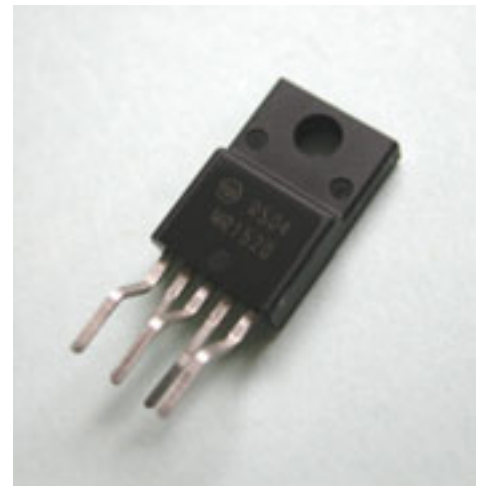

2

MR1000 Series Features

- > Implementation of a partial resonance power supply with a simple circuit configuration.
- > Use of the burst mode allows a reduction in standby power consumption. With a 100V input power supply, input power is approximately 100mW at no-load.
- > The module contains a start-up circuit to ensure stable start-up and to reduce start-up resistance.
- > Full implementation of all protective functions.

These features are described below.

Partial resonance power supplies are an effective means of increasing efficiency and reducing noise with a simple circuit configuration. Partial resonance operation requires detection of the secondary zero current (0A) point, and determination of the ON timing for the main switching device. The MR1000 Series incorporates a zero current detection pin (Z/C, pin 1), the negative edge of the voltage in the control coil (wound with opposite polarity to that of the primary coil) being detected in the main transformer and the main switching device switched ON to detect the 0A point of the secondary current. In order to switch the main switching device ON at the VDS resonance trough during partial resonance operation it is necessary to delay the ON timing for the primary inductance by 1/2 of the resonance period of the resonance condenser after the secondary current reaches 0A, and simple adjustment of the time constant of the resistor and condenser connected to the IC zero current detect pin (Z/C, pin 1) allows the main switching device to be switched ON at the VDS resonance trough.

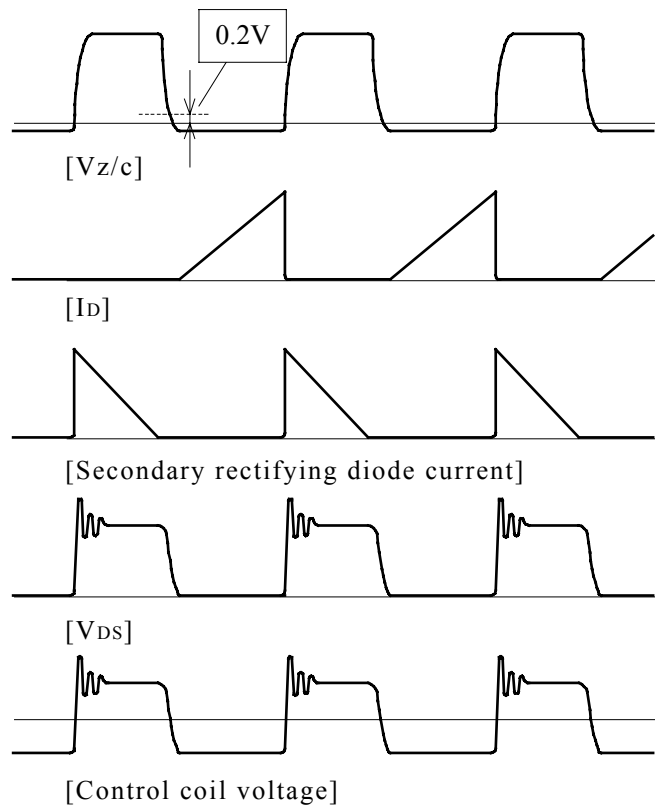

Fig.1 ON Trigger Operation Sequence

The MR1000 Series supports a function to reduce power consumption during standby by switching from the normal operation mode to the burst mode using an external signal. The voltage at pin (1) is clamped to a maximum of 2.9V (typ.) with a microcomputer standby signal to switch to the burst mode. Drain current is then limited to $I_{DP}(\text{burst}) = 425\text{mA}$ (typ.), and intermittent operation begins in which control of the ON width is switched from linear control of the voltage at the F/B pin (pin (2)) to hysteresis operation in which oscillation begins at $V_{F/B} > 1.8\text{V}$ and is halted at $V_{F/B} < 0.8\text{V}$.

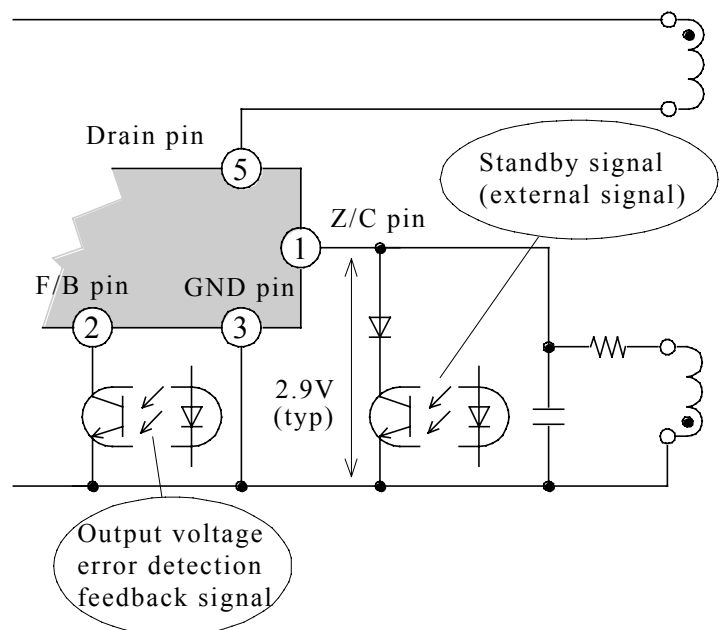

Fig.2 Standby Mode Selector Circuit

The burst method reduces switching losses by reducing the number of switching cycles per unit time, and is therefore a very effective method of reducing standby power consumption at very small loads. The MR1000 Series burst mode employs burst operation while controlling output, improving output ripple and transient response. Furthermore, as the IC control current also reduces circuit current wastage at burst oscillation and halt, unnecessary circuit operation is halted, reducing control current during normal operation by approximately half (comparison of normal operation at 50kHz and burst oscillation and halt).

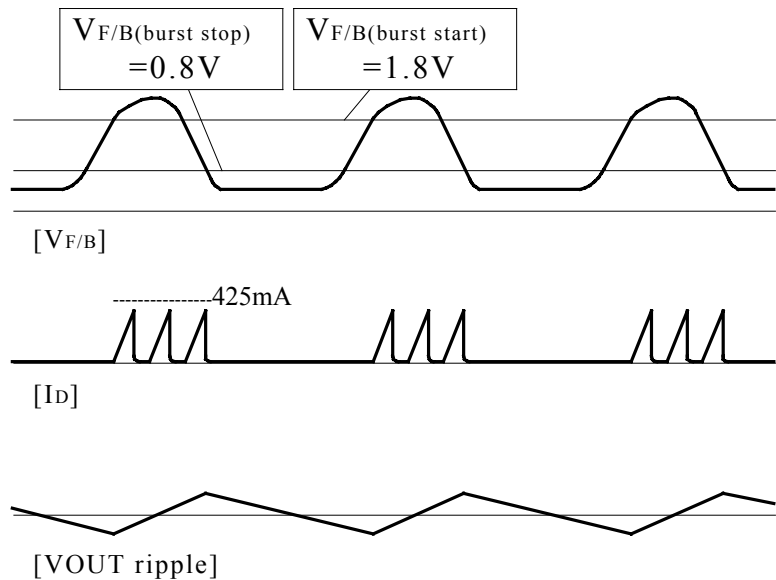

Fig.3 Standby Operation Sequence

2-3 Onboard Start-up Circuit

The IC incorporates a start-up circuit which is disconnected following power supply operation to reduce power wastage. This circuit is particularly effective in improving efficiency during standby, and as start-up current is limited to a fixed value, any change in start-up time is minimal despite changes in input voltage, and thus ensuring stable start-up characteristics.

2-4 Soft Drive

The MR1000 Series supplies gate current for the main switching device from two drive circuit systems. The first drive circuit system supplies a trigger voltage to switch the main switching device ON without delay and with the optimum timing. The second drive circuit system supplies a gate voltage at a constant current to the main switching device, reducing unnecessary gate drive power, and controlling steep gate charge currents to reduce noise.

2-5 Malfunction Protection Function

The MR1000 Series incorporates a circuit to prevent ON timing malfunctions and thus ensure that optimum partial resonance is maintained. At power supply ON and OFF, and in the case of a load short, linking of the transformer control coil voltage used in detecting ON timing is occurs readily when the main switching device is switched OFF, thus possibly resulting in a malfunction. The MR1000 Series incorporates an ON-dead timer to disable the ON trigger for a period of 2.5 μ s (typ.) after the main switching device is switched OFF, ensuring stable operation even under transient conditions. A Leading Edge Blank (LEB) function is also incorporated to prevent malfunctions due to resonance condenser discharge current and gate charge current.

The MR1000 Series detects excess current due to ON resistance, and thus allows reduction of primary current detection resistance and current detection losses. As over-current detection employs an internally fixed OCP value with ON resistance detection, the normal power limitation (power supply droop) is implemented with the ON width limit.

In addition to the above protection function, the overheat protection function (TSD: Thermal Shut-down) halts latching at 150°C(typ.), and the over-voltage protection function (OVP: Over-voltage Protection) halts latching at 20V at the Vcc pin.

Product Line-up

As shown below, the MR1000 Series may be used in configuring power supplies for maximum outputs of 50W (with 100V and 200V input systems) using the FT0-220 5-pin package.

Model	Absolute maximum rating		Maximum output capacity Po [W]		
	Peak input voltage	Peak input current	Input voltage range	Input voltage range	Input voltage range
	V _{in} [V]	I _{in} [A]	AC 85 ~ 132V	AC180 ~ 276V	AC 85 ~ 276V
MR 1520	500	5	50	-	-
MR 1721 *Currently under development.	700	2.5	-	50	25

Table 1 MR1000 Series Line-up

The following graphs illustrate efficiency (steady-state, standby), burst mode input power, and input feedback noise of the MR1520 standard power supply in Fig.6. Partial resonance operation improves efficiency in steady-state operation and reduces noise, and burst mode operation during standby reduces the number of switching cycles per unit time, thus reducing standby power consumption.

www.DataSheet4U.com

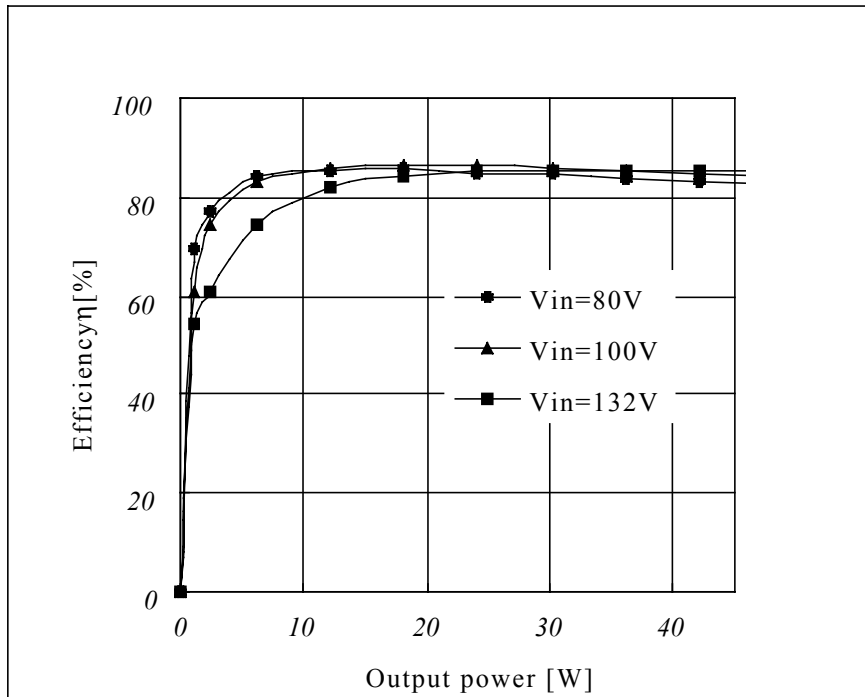

Fig.7 Efficiency Characteristics (steady-state)

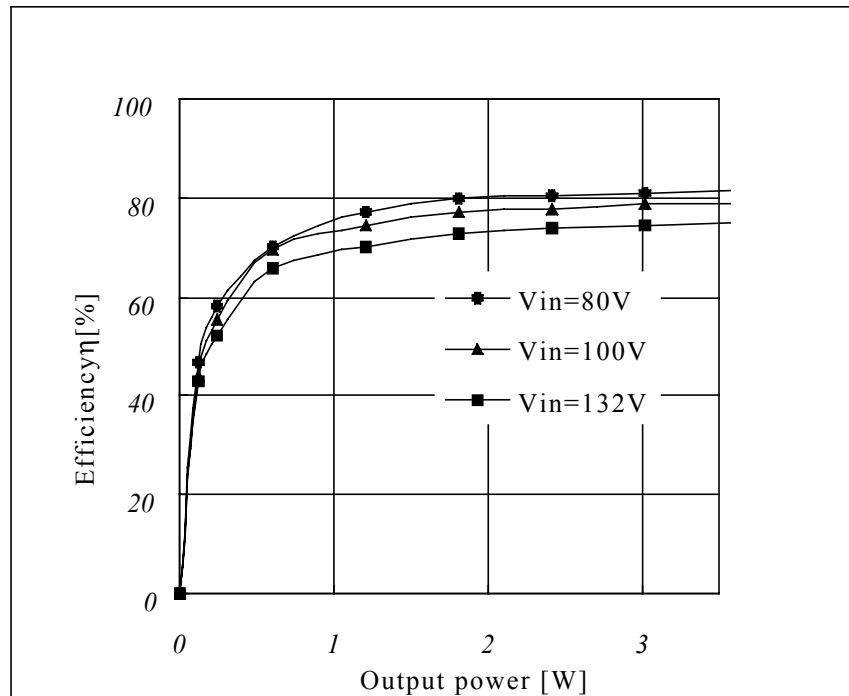

Fig.8 Efficiency Characteristics (standby)

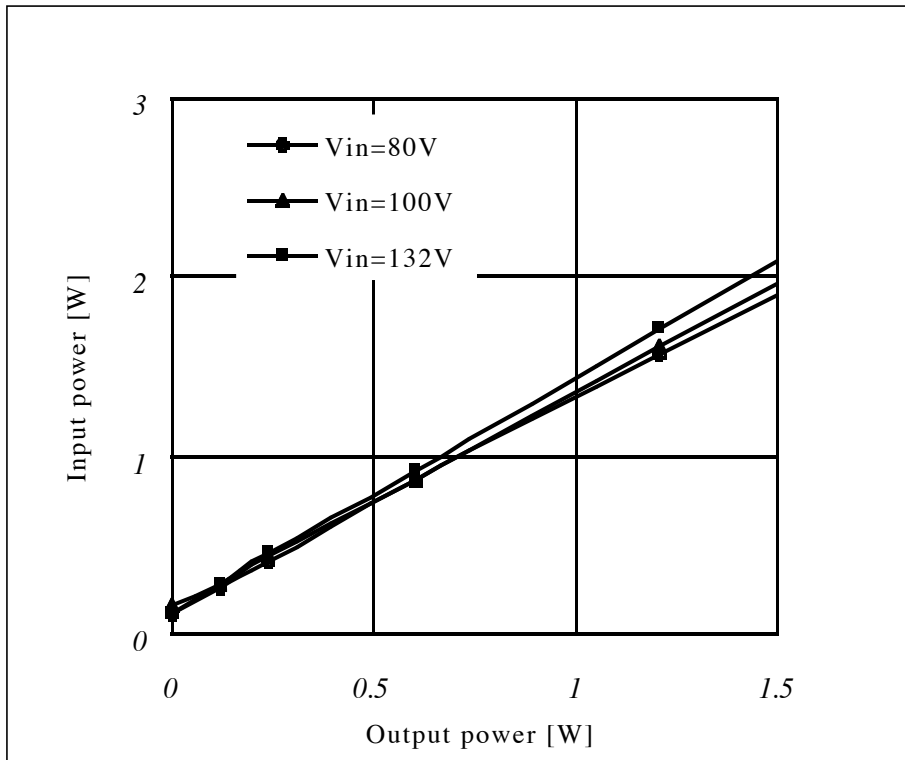

Fig.9 Standby Power Consumption

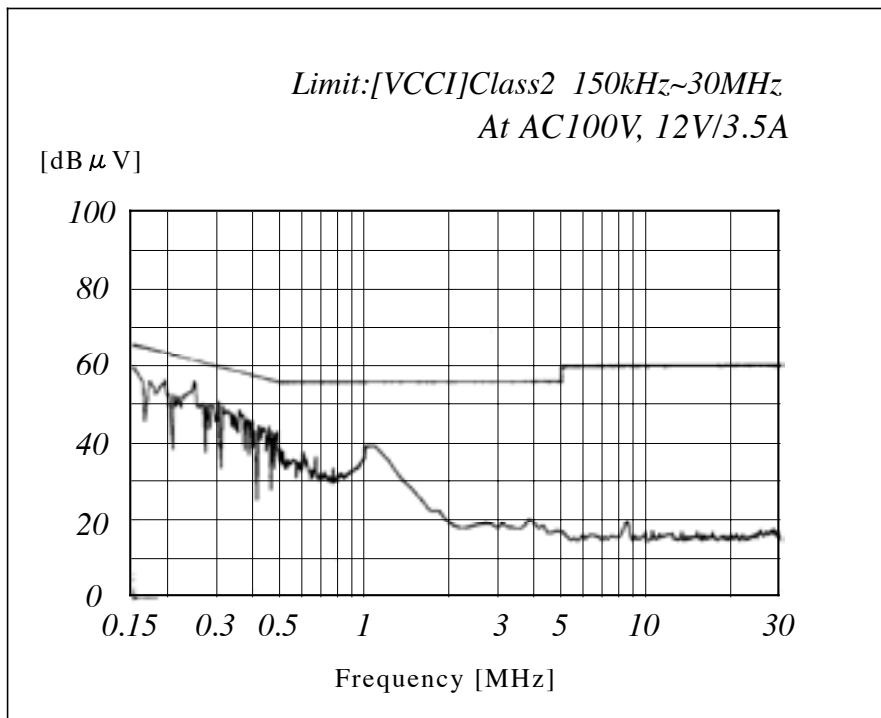

Fig.10 Input Feedback Noise

The MR1000 Series incorporates a start-up circuit, primary current detection resistance, various protection circuits, and various malfunction protection circuits in a single IC. This combination provides for a partial resonance power supply with full protection functions without the need for a large number of external components, and simplifies power supply design and reduces design time.

The standby function (burst mode) is controlled with an external signal, and allows reduction of the standby power consumption to approximately 100mW (100V input power supply) at no-load.

Future development of 25W small-capacity versions (100V and 200V input systems) is scheduled as part of a program of satisfying customer requirements through series expansion.